

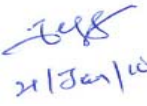

LS200

RELIABILITY

DATA

DWG. No. PA607-57-01		
APPD	CHK	DWG
 21/Jan/10	 21/Jan/10	

INDEX

	PAGE
1. Calculated Values Of MTBF	R-1
2. Component Derating	R-2
3. Main Components Temperature Rise ΔT List	R-7
4. Electrolytic Capacitor Life	R-9
5. Vibration Test	R-10
6. Noise Simulate Test	R-11
7. Abnormal Test	R-12
8. Thermal Shock Test	R-13

※ The above data is typical value. As all units have nearly the same characteristics, the data to be considered as ability value.

1. Calculated Values For MTBF

MODEL : LS200-5

1. Calculating Method

Calculated based on part count reliability projection of JEITA (RCR-9102).
Individual failure rates λ_G is given to each part and MTBF is calculated by the count of each part.

Formula :

$$\begin{aligned}
 \text{MTBF} &= \frac{1}{\lambda_{\text{equip}}} \\
 &= \frac{1}{\sum_{i=1}^n N_i (\lambda_G \pi_Q)_i} \times 10^6 \text{ (HOURS)}
 \end{aligned}$$

where :

λ_{equip} = Total Equipment Failure Rate (Failure / 10^6 Hours)

λ_G = Generic Failure Rate For The ith Generic Part (Failure / 10^6 Hours)

N_i = Quantity of ith Generic Part

n = Number of Different Generic Part Categories

π_Q = Generic Quality Factor for the ith Generic Part ($\pi_Q = 1$)

2. MTBF Values

G_F : (GROUND, FIXED)

MTBF : **299,149** Hours

(MTBF Calculation Exclude Fan)

2. Component Derating

MODEL : LS200-5

(1) Calculating Method

(a) Measuring Conditions

Input Voltage	: 115VAC, 230VAC
Output Voltage	: 5V
Output Current	: 100%
Ambient temperature	: 50°C
Mounting method	: Mounting A

(b) Semiconductors

Compared with maximum junction temperature and actual one which is calculated based on case temperature, power dissipation and thermal impedance.

(c) IC, Resistors, Capacitors, etc.

Ambient temperature, operating condition, power dissipation and so on are within derating criteria.

(d) Calculating Method of Thermal Impedance

$$\theta_{j-c} = \frac{T_{j(\max)} - T_c}{P_{c(\max)}} \quad \theta_{j-a} = \frac{T_{j(\max)} - T_a}{P_{c(\max)}} \quad \theta_{j-l} = \frac{T_{j(\max)} - T_l}{P_{c(\max)}}$$

T_c : Case temperature at start point of derating ; 25°C in general

T_a : Ambient temperature at start point of derating ; 25°C in general

T_j : Lead temperature at start point of derating ; 25°C in general

$P_{c(\max)}$: Maximum collector(channel) dissipation
($P_{ch(\max)}$)

$T_{j(\max)}$: Maximum junction(channel) temperature
($T_{ch(\max)}$)

(θ_{j-c}) : Thermal impedance between junction(channel) and case
(θ_{ch-c})

θ_{j-a} : Thermal impedance between junction and air

θ_{j-l} : Thermal impedance between junction and lead

2. Component Derating

MODEL : LS200

(2) Component Derating List

Location No.	Vin =115VAC	Load = 100%	Ta = 50°C
Q1 IPP50R250CP INFINEON	Tchmax = 150°C, Pch = 12.822W, Tch = Tc + ((θ ch-c) × Pch) = 104.70°C D.F. = 69.8%	θ ch-c = 1.1°C/W, Δ Tc = 40.6°C,	Pchmax = 114 W Tc = 90.6°C
Q2 FQA9N90C_F109 FAIRCHILD	Tchmax = 150°C, Pch = 12.970W, Tj = Tc + ((θ j-c) × Pch) = 116.10°C D.F. = 77.4%	θ ch-c = 0.45°C/W, Δ Tc = 60.3°C,	Pchmax = 280 W Tc = 110.3°C
Q6 2SC2655-Y(TPE6,F) TOSHIBA	Tjmax = 150°C, Pj = 0.097W, Tj = Ta + ((θ j-a) × Pj) = 101.10°C D.F. = 67.4%	θ ch-a = 139°C/W Δ Ta = 37.6°C	Pjmax = 0.9 W Ta = 87.6°C
D1 RS1505M RECTRON	Tjmax = 150°C, Pc = 3.553W, Tj = Tl + ((θ j-c) × Pc) = 97.53°C D.F. = 65.0%	θ j-c = 1.5°C/W Δ Tc = 42.2°C	Tc = 92.2°C
D4 YG911S3R FUJI ELECTRIC	Tjmax = 150°C, Pd = 1.513W, Tj = Tc + ((θ j-c) × Pd) = 104.50°C D.F. = 69.7%	θ j-c = 3.5°C/W, Δ Tc = 49.2°C,	Tc = 99.2°C
D5 CMF05(TE12L,DSL,AQ) TOSHIBA	Tjmax = 150°C, Pd = 0.0575W, Tj = T1 + ((θ j-1) × Pd) = 119.52°C D.F. = 79.7%	θ j-1 = 16°C/W, Δ T1 = 68.6°C,	T1 = 118.6°C
D8 CRH01(TE85L,F) TOSHIBA	Tjmax = 150°C, Pd = 0.040W, Tj = Ta + ((θ j-a) × Pd) = 85.80°C D.F. = 57.2%	θ j-a = 65°C/W, Δ Ta = 33.2°C,	Ta = 83.2°C
D10 CRH01(TE85L,F) TOSHIBA	Tjmax = 150°C, Pd = 0.040W, Tj = Tc + ((θ j-c) × Pd) = 104.50°C D.F. = 69.7%	θ j-a = 65°C/W, Δ Ta = 51.9°C	Ta = 101.9°C
D11 S30SC4MT-5000 SHINDENGEN	Tjmax = 150°C, Pd = 10.400W, Tj = Tc + ((θ j-c) × Pd) = 127.12°C D.F. = 84.7%	θ j-c = 0.8°C/W, Δ Tc = 68.8°C,	Tc = 118.8 °C
D12 S30SC4MT-5000 SHINDENGEN	Tjmax = 150°C, Pd = 10.400W, Tj = Tc + ((θ j-c) × Pd) = 127.12°C D.F. = 84.7%	θ j-c = 0.8°C/W, Δ Tc = 68.8°C,	Tc = 118.8 °C
D13 CRH01(TE85L,F) TOSHIBA	Tjmax = 150°C, Pd = 0.130W, Tj = Ta + ((θ j-a) × Pd) = 100.25°C D.F. = 66.8%	θ j-a = 65°C/W, Δ Ta = 41.8°C,	Ta = 91.8°C
Z3 02CZ18-Z(TE85L,F) TOSHIBA	Tjmax = 150°C, Pc = 0.015W, Tj = Ta + ((θ j-a) × Pc) = 92.39°C D.F. = 61.6%	θ j-a = 625°C/W, Δ Ta = 33.2°C,	Ta = 83.2°C
Z4 HZ24-1TA-N-EQ RENESAS	Tjmax = 150°C, Pc = 0.087W, Tj = Ta + ((θ j-a) × Pc) = 121.79°C D.F. = 81.2%	θ j-a = 350°C/W, Δ Ta = 41.3°C,	Ta = 91.3°C

2. Component Derating

MODEL : LS200

(2) Component Derating List

Location No.	Vin =115VAC	Load = 100%	Ta = 50°C
PC1 PS256BL1-1-A(D) TRANSISTOR NEC	Tjmax = 125°C, Pc = 0W, Tj = Tc + ((θ j-c) × Pc) = 87.60°C D.F. = 70.1%	θ j-a = 667°C/W, Δ Tc = 37.6 °C,	Tc = 87.6°C
PC1 PS256BL1-1-A(D) LED NEC	Tjmax = 125°C, Pd = 0W, Tj = Tc + ((θ j-c) × Pd) = 87.60°C D.F. = 70.1%	θ j-a = 667°C/W, Δ Tc = 37.6°C,	Tc = 87.6°C
PC2 PS256BL1-1-A(D) TRANSISTOR NEC	Tjmax = 125°C, Pd = 0W, Tj = Tc + ((θ j-c) × Pd) = 90.50°C D.F. = 70.1%	θ j-a = 667°C/W, Δ Tc = 37.6°C,	Tc = 87.6°C
PC2 PS256BL1-1-A(D) LED NEC	Tjmax = 125°C, Pd = 0W, Tj = Tc + ((θ j-c) × Pd) = 90.50°C D.F. = 70.1%	θ j-a = 667°C/W, Δ Tc = 37.6°C,	Tc = 87.6°C
PC3 PS256BL1-1-A(D) TRANSISTOR NEC	Tjmax = 125°C, Pd = 8.54mW, Tj = Tc + ((θ j-c) × Pd) = 93.29°C D.F. = 74.6%	θ j-a = 667°C/W, Δ Tc = 37.6°C,	Tc = 87.6°C
PC3 PS256BL1-1-A(D) LED NEC	Tjmax = 125°C, Pd = 1.1mW, Tj = Tc + ((θ j-c) × Pd) = 88.30°C D.F. = 70.6%	θ j-a = 667°C/W, Δ Tc = 37.6°C,	Tc = 87.6°C
A1 ICE2PCS03G INFINEON	Tchmax = 150°C, Pd = 0.152W, Tj = Ta + ((θ j-a) × Pd) = 125.80°C D.F. = 83.9%	θ ch-a = 185°C/W, Δ Ta = 47.7°C,	Ta = 97.7°C
A2 M51995AFP CF0J RENESAS	Tchmax = 150°C, Pd = 0.381W, Tj = Tc + ((θ j-c) × Pd) = 126.75°C D.F. = 84.5%	θ ch-c = 40°C/W, Δ Tc = 61.5°C,	Tc = 111.5°C
A3 TL431AILPR TI	Tjmax = 150°C, Pd = 0.043W, Tj = Ta + ((θ j-a) × Pd) = 83.43°C D.F. = 55.6%	θ ch-a = 156°C/W, Δ Ta = 26.7°C,	Ta = 76.7°C
A4 LM393AP TI	Tjmax = 150°C, Pd = 0.012W, Tj = Ta + ((θ j-a) × Pd) = 72.62°C D.F. = 48.4%	θ ch-a = 85°C/W, Δ Ta = 21.6°C,	Ta = 71.6°C
A5 KIA78M12PI KEC	Tjmax = 150°C, Pd = 1.556W, Tj = Tc + ((θ j-c) × Pd) = 109.34°C D.F. = 72.9%	θ ch-c = 6°C/W, Δ Tc = 50.0°C,	Tc = 100.0°C

2. Component Derating

MODEL : LS200

(2) Component Derating List

Location No.	Vin = 230VAC	Load = 100%	Ta = 50°C
Q1 IPP50R250CP INFINEON	Tchmax = 150°C, Pch = 6.874W, Tch = Tc + ((θ ch-c) × Pch) = 84.50°C D.F. = 56.3%	θ ch-c = 1.1°C/W, Δ Tc = 26.9°C,	Pchmax = 114 W Tc = 76.9°C
Q2 FQA9N90C_F109 FAIRCHILD	Tchmax = 150°C, Pch = 12.970W, Tj = Tc + ((θ j-c) × Pch) = 109.40°C D.F. = 73.0%	θch-c = 0.45°C/W, Δ Tc = 53.6°C,	Pchmax = 280 W Tc = 103.6°C
Q6 2SC2655-Y(TPE6,F) TOSHIBA	Tjmax = 150°C, Pj = 0.088W, Tj = Ta + ((θ j-a) × Pj) = 91.30°C D.F. = 60.9%	θ ch-a = 139°C/W Δ Ta = 29.1°C	Pjmax = 0.9 W Ta = 79.1°C
D1 RS1505M RECTRON	Tjmax = 150°C, Pc = 1.872W, Tj = Tl + ((θ j-c) × Pc) = 76.31°C D.F. = 50.9%	θ j-c = 1.5°C/W Δ Tc = 23.5°C	Tc = 73.5°C
D4 YG911S3R FUJI ELECTRIC	Tjmax = 150°C, Pd = 1.513W, Tj = Tc + ((θ j-c) × Pd) = 89.80°C D.F. = 59.9%	θ j-c = 3.5°C/W, Δ Tc = 34.5°C,	Tc = 84.5°C
D5 CMF05(TE12L,DSL,AQ) TOSHIBA	Tjmax = 150°C, Pd = 0.0575W, Tj = T1 + ((θ j-1) × Pd) = 115.82°C D.F. = 77.2%	θ j-1 = 16°C/W, Δ T1 = 64.9°C,	T1 = 114.9°C
D6 D1FL20U-7063 SHINDENGEN	Tjmax = 150°C, Pd = 0.002W, Tj = T1 + ((θ j-1) × Pd) = 93.15°C D.F. = 62.1%	θ j-1 = 23°C/W, Δ T1 = 43.1°C,	T1 = 93.1°C
D10 CRH01(TE85L,F) TOSHIBA	Tjmax = 150°C, Pd = 0.040W, Tj = Tc + ((θ j-c) × Pd) = 102.90°C D.F. = 68.6%	θ j-a = 65°C/W, Δ Ta = 50.3C,	Ta = 100.3°C
D11 S30SC4MT-5000 SHINDENGEN	Tjmax = 150°C, Pd = 10.400W, Tj = Tc + ((θ j-c) × Pd) = 109.13°C D.F. = 62.4%	θ j-c = 0.8°C/W, Δ Tc = 67.7°C,	Tc = 117.7°C
D12 S30SC4MT-5000 SHINDENGEN	Tjmax = 150°C, Pd = 10.400W, Tj = Tc + ((θ j-c) × Pd) = 109.13°C D.F. = 62.4%	θ j-c = 0.8°C/W, Δ Tc = 67.7°C,	Tc = 117.7°C
D13 CRH01(TE85L,F) TOSHIBA	Tjmax = 150°C, Pd = 0.140W, Tj = Ta + ((θ j-a) × Pd) = 101.00°C D.F. = 67.3%	θ j-a = 65°C/W, Δ Ta = 41.9°C,	Ta = 91.9°C
Z3 02CZ18-Z(TE85L,F) TOSHIBA	Tjmax = 150°C, Pc = 0.015W, Tj = Ta + ((θ j-a) × Pc) = 81.89°C D.F. = 54.6%	θ j-a = 625°C/W, Δ Ta = 22.7°C,	Ta = 72.7°C
Z4 HZ24-1TA-N-EQ RENESAS	Tjmax = 150°C, Pc = 0.087W, Tj = Ta + ((θ j-a) × Pc) = 114.59°C D.F. = 76.4%	θ j-a = 350°C/W, Δ Ta = 34.1°C,	Ta = 84.1°C

2. Component Derating

MODEL : LS200

(2) Component Derating List

Location No.	Vin = 230VAC	Load = 100%	Ta = 50°C
PC1 PS256BL1-1-A(D) TRANSISTOR NEC	Tjmax = 125°C, Pc = 0W, Tj = Tc + ((θ j-c) × Pc) = 86.30°C D.F. = 69.0%	θ j-a = 667°C/W, Δ Tc = 36.3 °C,	Tc = 86.3°C
PC1 PS256BL1-1-A(D) LED NEC	Tjmax = 125°C, Pd = 0W, Tj = Tc + ((θ j-c) × Pd) = 86.30°C D.F. = 69.0%	θ j-a = 667°C/W, Δ Tc = 36.3°C,	Tc = 86.3°C
PC2 PS256BL1-1-A(D) TRANSISTOR NEC	Tjmax = 125°C, Pd = 0W, Tj = Tc + ((θ j-c) × Pd) = 86.30°C D.F. = 69.0%	θ j-a = 667°C/W, Δ Tc = 36.3°C,	Tc = 86.3°C
PC2 PS256BL1-1-A(D) LED NEC	Tjmax = 125°C, Pd = 0W, Tj = Tc + ((θ j-c) × Pd) = 86.30°C D.F. = 69.0%	θ j-a = 667°C/W, Δ Tc = 36.3°C,	Tc = 86.3°C
PC3 PS256BL1-1-A(D) TRANSISTOR NEC	Tjmax = 125°C, Pd = 8.54mW, Tj = Tc + ((θ j-c) × Pd) = 92.00°C D.F. = 73.6%	θ j-a = 667°C/W, Δ Tc = 36.3°C,	Tc = 86.3°C
PC3 PS256BL1-1-A(D) LED NEC	Tjmax = 125°C, Pd = 1.1mW, Tj = Tc + ((θ j-c) × Pd) = 87.00°C D.F. = 69.6%	θ j-a = 667°C/W, Δ Tc = 36.3°C,	Tc = 86.3°C
A1 ICE2PCS03G INFINEON	Tchmax = 150°C, Pd = 0.152W, Tj = Ta + ((θ j-a) × Pd) = 117.40°C D.F. = 78.3%	θ ch-a = 185°C/W, Δ Ta = 39.3C,	Ta = 89.3°C
A2 M51995AFP CF0J RENESAS	Tchmax = 150°C, Pd = 0.381W, Tj = Tc + ((θ j-c) × Pd) = 123.35°C D.F. = 82.2%	θ ch-c = 40°C/W, Δ Tc = 58.1°C,	Tc = 108.1°C
A3 TL431AILPR TI	Tjmax = 150°C, Pd = 0.043W, Tj = Ta + ((θ j-a) × Pd) = 83.83°C D.F. = 55.9%	θ ch-a = 156°C/W, Δ Ta = 27.1°C,	Ta = 72.8°C
A4 LM393AP TI	Tjmax = 150°C, Pd = 0.012W, Tj = Ta + ((θ j-a) × Pd) = 70.90°C D.F. = 47.3%	θ ch-a = 85°C/W, Δ Ta = 20.9°C,	Ta = 70.9°C
A5 KIA78M12PI KEC	Tjmax = 150°C, Pd = 1.556W, Tj = Tc + ((θ j-c) × Pd) = 108.04°C D.F. = 72.0%	θ ch-c = 6°C/W, Δ Tc = 48.7°C,	Tc = 98.7°C

3. Main Components Temperature Rise ΔT List

MODEL : LS200-5

Conditions :

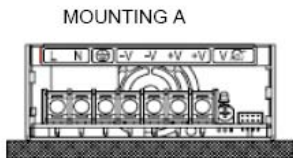
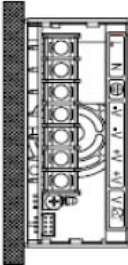
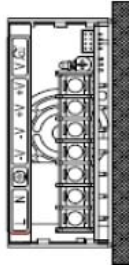
Mounting Method	 <p>MOUNTING A</p>	 <p>MOUNTING B</p>	 <p>MOUNTING C</p>
	Input Voltage (VAC)	115	
Output Voltage (VDC)	5		
Output Current (A)	40		

Output Derating $T_a = 50^\circ\text{C}$		ΔT Temperature Rise ($^\circ\text{C}$)	
		$I_o = 100\%$	
Location No	Parts Name	Mounting (A), (B) & (C)	
Q1	MOSFET	40.6	
Q2	MOSFET	60.3	
D1	BRIDGE DIODE	42.2	
D4	F.R.D.	49.2	
D11	S.B.D	68.8	
A1	CHIP IC	47.7	
A2	CHIP IC	61.5	
A3	SHUNT REGULATOR	26.7	
A4	IC	21.6	
A5	IC	50.0	
C1	CAP. FILM	5.8	
C6	CAP. FILM	21.2	
C10	CAP. ELECT	33.6	
C36	CAP. ELECT	30.8	
C37	CAP. ELECT	33.8	
R84	CHIP RESISTOR	76.7	
TH1	THERMISTOR	57.7	
L1	BALUN COIL	9.9	
L5	CHOKE COIL	49.7	
L14	CHOKE COIL	54.2	
T1	TRANS. PULSE	58.3	

3. Main Components Temperature Rise ΔT List

MODEL : LS200-5

Conditions :

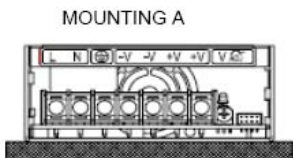
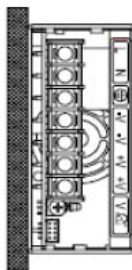
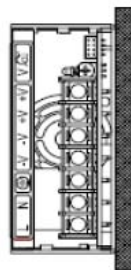
Mounting Method	 <p>MOUNTING A</p>	 <p>MOUNTING B</p>	 <p>MOUNTING C</p>
	Input Voltage (VAC)	230	
Output Voltage (VDC)	5		
Output Current (A)	40		

Output Derating $T_a = 50^\circ\text{C}$		ΔT Temperature rise ($^\circ\text{C}$)
		$I_o = 100\%$
Location No	Parts Name	Mounting (A), (B) & (C)
Q1	MOSFET	26.9
Q2	MOSFET	53.6
D1	BRIDGE DIODE	23.5
D4	F.R.D.	34.5
D11	S.B.D.	67.7
A1	CHIP IC	39.3
A2	CHIP IC	58.1
A3	SHUNT REGULATOR	27.1
A4	IC	20.9
A5	IC	48.7
C1	CAP. FILM	4.4
C6	CAP. FILM	13.0
C10	CAP. ELECT	24.8
C36	CAP. ELECT	31.3
C37	CAP. ELECT	34.6
R84	CHIP RESISTOR	76.4
TH1	THERMISTOR	34.5
L1	BALUN COIL	9.9
L5	CHOKE COIL	32.1
L14	CHOKE COIL	47.2
T1	TRANS. PULSE	55.6

4. Electrolytic Capacitor Life

MODEL : LS200-5

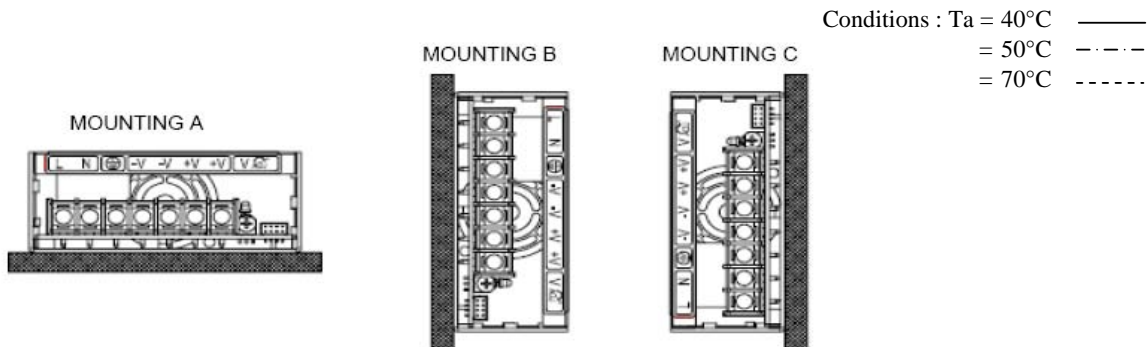

Vin = 115VAC

Load (%)	Life Time (year)		
	Ta = 40°C	Ta = 50°C	Ta = 70°C
50	10.0	10.0	3.9
60	10.0	10.0	3.3
70	10.0	10.0	2.6
80	10.0	8.5	2.1
90	10.0	6.4	1.6
100	9.3	4.7	1.2

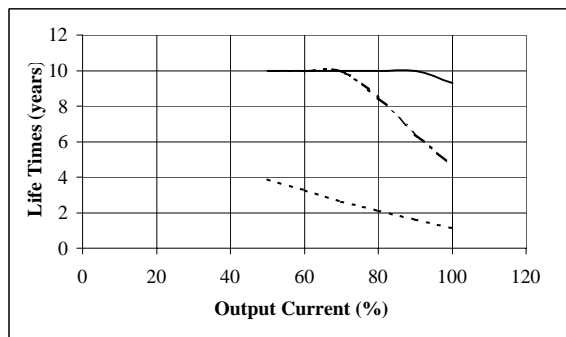

Vin = 230VAC

Load (%)	Life Time (year)		
	Ta = 40°C	Ta = 50°C	Ta = 70°C
50	10.0	10.0	4.8
60	10.0	10.0	4.0
70	10.0	10.0	3.5
80	10.0	10.0	3.0
90	10.0	9.7	2.4
100	10.0	7.9	2.0

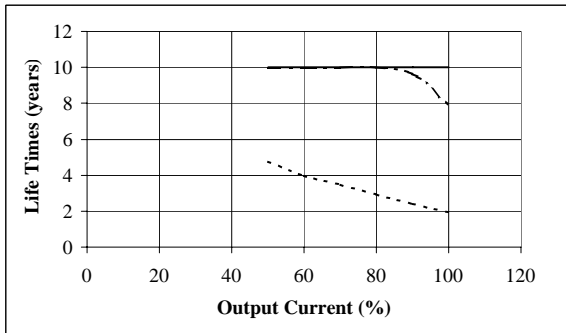

Note : E-cap life calculation is based on 8hrs/day operation.

5. Vibration Test

MODEL : LS200-5

(1) Vibration Test Class

Frequency Variable Endurance Test

(2) Equipment Used

Controller : F-400-BM-E47 (EMIC CORP.)
 Vibrator : 905-FN (EMIC CORP.)
 Serial no. : 22965

(3) The Number Of D.U.T. (Device Under Test)

1 Unit

(4) Test Conditions

Sweep Frequency	: 10 - 55Hz	Direction	: X, Y, Z
Sweep Time	: 1 minute	Test Time	: 1 hour each axis
Acceleration	: 2G	Non-operation	
Mounting	: A and B		

(5) Test Method

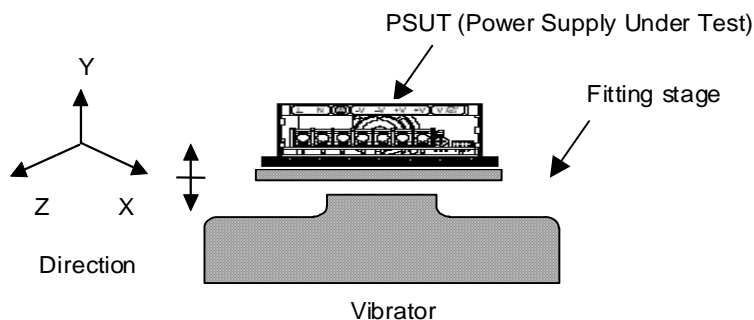

Fix the PSUT on the universal plate via two M3 tapped holes on the chassis of the power supply. Standard mounting position as per test specification.

(6) Test Results : OK

Test conditions : Vin = 230VAC
 Ambient Temp. = 25°C
 Iout = 100%

Check Item	Output Voltage (V)	PSUT State
Before Test	5.011	—————
After Test	X	OK
	Y	OK
	Z	OK

6. Noise Simulation Test

MODEL : LS200-5

(1) Test Circuit and Equipment

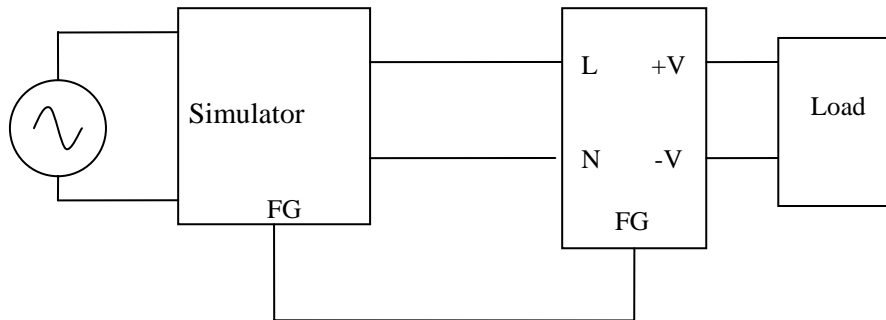

Simulator : INS-400L Noise Laboratory Co.,LTD

(2) Test Conditions

- | | | | |
|-----------------------|---------------|------------------|------------------|
| • Input voltage | : 115, 230VAC | • Noise level | : 0V~2.4kV |
| • Output voltage | : Rated | • Phase shift | : 0°~360° |
| • Output current | : 0%, 100% | • Polarity | : +, - |
| • Ambient temperature | : 25°C | • Mode | : Normal, Common |
| • Pulse Width | : 0ns~1000ns | • Trigger select | : Line |

(3) Acceptable Conditions

1. Not to be broken.
2. No output shutdown.
3. No other out of order.

(4) Test result : OK

7. Abnormal Test

MODEL : LS200-5

(1) Test Conditions

Input Voltage : 230VAC Output Current : 100% Ta : 25°C

(2) Test Results

(Da: Damaged)

No.	Test Position		Test Mode		Test Results												NOTE
	LOCATION	TEST POINT	SHORT	OPEN	1	2	3	4	5	6	7	8	9	10	11	12	
1	D1	1 - 2 (+VE to AC)	•							•	•			•			Da : F1
		3 - 4 (AC to -VE)	•							•	•			•			
2	Q1	D - S	•							•	•			•			Da : F1
		D - G	•							•	•			•			Da : F1, Q1, A1
		G - S	•											•			
3	Q2	D - S	•		•					•	•			•			Da : F1, D6, R11, R12, R49
		D - G	•							•	•			•			Da : F1, Z2
		G - S	•											•			
4	A3	1 - 2 (Ref to Anode)	•										•	•			
5	PC3	3 - 4	•											•			
		3		•									•	•			
6	T1	1 - 2	•													•	Hiccup
		4 - 6	•											•			
		5 - 7	•													•	Hiccup
7	C10	(+) Bulk - (-) Bulk	•											•			
				•						•				•			Da : D20

8. Thermal Shock Test

MODEL : LS200-5

(1) Equipment Used

THERMAL SHOCK CHAMBER TSA-101S-W (ESPEC CORP.)

(2) The Number Of D.U.T. (Device Under Test)

1 unit

(3) Test Conditions

- Ambient temperature : -40°C ↔ 85°C
- Test time : 30 mins each temp.
- Test cycle : 100 cycles
- Not operating

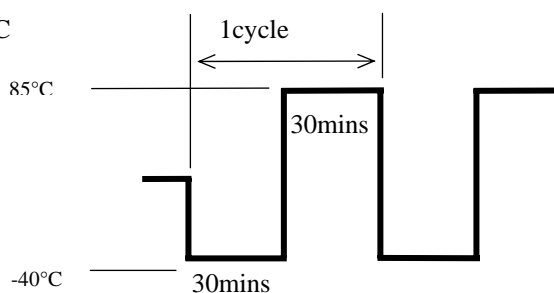

(4) Test Method

Before testing, check if there is no abnormal output, then put the D.U.T. in testing chamber, and test it according to the above cycle. 100 cycles later, leave it for 1 hour at the room temperature, then check if there is no abnormal output.

(5) Test Results : OK

Vin : 230VAC Io : 100%			From	To		
Ripple & Spike noise		mVpp	47.20	52.00		
Line Regulation	Full load	mV	0.00	1.00		
Load Regulation	Vin : 230V	mV	34.00	33.00		
Efficiency	Pin	W	261.67	76.41%	261.81	76.20%
	Vout	V	4.999		4.988	
	Iout	A	40.00		40.00	
Solder condition • etc.			—————	OK		